



DEPARTMENT OF REGULATORY AND ECONOMIC RESOURCES (RER)
BOARD AND CODE ADMINISTRATION DIVISION
NOTICE OF ACCEPTANCE (NOA)

MIAMI-DADE COUNTY
PRODUCT CONTROL SECTION
11805 SW 26 Street, Room 208
Miami, Florida 33175-2474
T (786) 315-2590 F (786) 315-2599
www.miamidade.gov/economy

United Enertech Holdings, LLC
3005 South Hickory Street
Chattanooga, TN 37407

SCOPE:

This NOA is being issued under the applicable rules and regulations governing the use of construction materials. The documentation submitted has been reviewed and accepted by Miami-Dade County RER-Product Control Section to be used in Miami Dade County and other areas where allowed by the Authority Having Jurisdiction (AHJ).

This NOA shall not be valid after the expiration date stated below. The Miami-Dade County Product Control Section (In Miami Dade County) and/or the AHJ (in areas other than Miami Dade County) reserve the right to have this product or material tested for quality assurance purposes. If this product or material fails to perform in the accepted manner, the manufacturer will incur the expense of such testing and the AHJ may immediately revoke, modify, or suspend the use of such product or material within their jurisdiction. RER reserves the right to revoke this acceptance, if it is determined by Miami-Dade County Product Control Section that this product or material fails to meet the requirements of the applicable building code.

This product is approved as described herein and has been designed to comply with the Florida Building Code, including the High Velocity Hurricane Zone.

DESCRIPTION: Model WDV-130 Vertical Aluminum Louver System

APPROVAL DOCUMENT: Drawing No. **19-092**, titled "Model WDV-130 Vertical Aluminum Louver System", sheets 1 through 6 of 6, dated 09/24/2019, prepared by Tilteco, Inc., signed and sealed by Walter A. Tillit Jr., P.E. on 01/20/2020, bearing the Miami-Dade County Product Control approval stamp with the Notice of Acceptance number and approval date by the Miami-Dade County Product Control Section.

MISSILE IMPACT RATING: Large and Small Missile Impact Resistant.

LABELING: A permanent label with the manufacturer's name or logo, Chattanooga, TN or Hartford, AL, model/series, and following statement: "Miami-Dade County Product Control Approved", is to be located on each unit.

RENEWAL of this NOA shall be considered after a renewal application has been filed and there has been no change in the applicable building code negatively affecting the performance of this product.

TERMINATION of this NOA will occur after the expiration date or if there has been a revision or change in the materials, use, and/or manufacture of the product or process. Misuse of this NOA as an endorsement of any product, for sales, advertising or any other purposes shall automatically terminate this NOA. Failure to comply with any section of this NOA shall be cause for termination and removal of NOA.

ADVERTISEMENT: The NOA number preceded by the words Miami-Dade County, Florida, and followed by the expiration date may be displayed in advertising literature. If any portion of the NOA is displayed, then it shall be done in its entirety.

INSPECTION: A copy of this entire NOA shall be provided to the user by the manufacturer or its distributors and shall be available for inspection at the job site at the request of the Building Official.

This NOA consists of this page 1 and evidence page E-1, as well as approval document mentioned above. The submitted documentation was reviewed by **Carlos M. Utrera, P.E.**



Handwritten signature and date: 02/14/2020

NOA No. 20-0109.02
Expiration Date: February 27, 2025
Approval Date: February 27, 2020
Page 1

NOTICE OF ACCEPTANCE: EVIDENCE SUBMITTED

A. DRAWINGS

1. Drawing No. **19-092**, titled "Model WDV-130 Vertical Aluminum Louver System", sheets 1 through 6 of 6, dated 09/24/2019, prepared by Tilteco, Inc., signed and sealed by Walter A. Tillit Jr., P.E. on 01/20/2020.

B. TESTS

1. Test reports on 1) Uniform Static Air Pressure Test, Loading per FBC TAS 202-94
2) Large Missile Impact Test per FBC, TAS 201-94 (Level "E", 80 fps)
3) Cyclic Wind Pressure Loading per FBC, TAS 203-94
along with marked-up drawings and installation diagram of Model WDV-130 Vertical Aluminum Louver Systems, prepared by PRI Construction Materials Technologies LLC, Test Report No. **1697T0001.01.01**, dated 11/20/2019, signed and sealed by Zachary Priest, P.E. on 01/27/2020.
2. Test Report on High Velocity Wind Driven Rain Resistance Test per ANSI/AMCA 550-15 of a Model WDV-130 Vertical Aluminum Louver System, prepared by PRI Construction Materials Technologies LLC, Report No. **1697T0001.02**, dated 10/16/2019, signed and sealed by Zachary Priest, P.E.

C. CALCULATIONS

1. Structural analysis and anchor calculations, prepared by Tilteco Inc, dated 09/30/2019, signed and sealed by Walter A. Tillit Jr., P.E.

D. QUALITY ASSURANCE

1. Miami-Dade Department of Regulatory and Economic Resources (RER)

E. MATERIAL CERTIFICATIONS

1. Test Report on Large Missile Impact (Level "E", 80 fps) Test per ANSI/AMCA 540-13 and Cyclic Wind Pressure Loading per FBC, TAS 203-94 of Model WDV-130 Vertical Aluminum Louver Systems, prepared by PRI Construction Materials Technologies LLC, Report No. **1697T0001.03**, dated 11/20/2019, signed and sealed by Zachary Priest, P.E.

F. STATEMENTS

1. Statement letter of code conformance to the 6th edition (2017) FBC issued by Tilteco, Inc. on 11/26/2019, signed and sealed by Walter A. Tillit Jr., P.E.
2. Statement letter of no financial interest letter issued by Tilteco, Inc., dated 11/26/2019, signed and sealed by Walter A. Tillit Jr., P.E.
3. Letter requesting the company name change from "United Enertech Corp." to its parent company, "United Enertech Holdings, LLC", issued by Winstead PC, dated 01/31/2020, signed by Andrew J. Ostapko, Attorney.
4. Certificate of merger between "United Enertech Corp." and "Enertech Acquisition Corp.", issued by the State of Delaware, dated 01/04/2017.
5. Amended and restated certificate of incorporation of "United Enertech Corp." (F/K/A "Enertech Acquisition Corp.", issued by the State of Delaware, dated 12/30/2016.
6. Certificate of formation of "United Enertech Holdings, LLC", issued by the State of Delaware, dated 12/02/2016.

02/14/2020

Carlos M. Utrera, P.E.
Product Control Examiner
NOA No. 20-0109.02

Expiration Date: February 27, 2025
Approval Date: February 27, 2020

GENERAL NOTES

1. MODEL WDV-130 VERTICAL ALUMINUM LOUVER SYSTEM SHOWN ON THIS PRODUCT APPROVAL DOCUMENT (P.A.D.) HAS BEEN VERIFIED FOR COMPLIANCE IN ACCORDANCE WITH THE 2017 (6th EDITION) OF THE FLORIDA BUILDING CODE. THIS ALUMINUM LOUVER SYSTEM MAY BE INSTALLED AT HIGH VELOCITY HURRICANE ZONES.

DESIGN WIND LOADS SHALL BE DETERMINED AS PER SECTION 1620 OF THE ABOVE MENTIONED CODE, USING ASCE 7-10 AND SHALL NOT EXCEED THE MAXIMUM (A.S.D.) DESIGN PRESSURE RATINGS INDICATED ON THIS SHEET.

IN ORDER TO VERIFY THE ABOVE CONDITION, ULTIMATE DESIGN WIND LOADS DETERMINED PER ASCE 7-10 SHALL BE FIRST REDUCED TO A.S.D. DESIGN WIND LOADS BY MULTIPLYING THEM BY 0.6 IN ORDER TO COMPARE THESE W/ MAX. (A.S.D.) DESIGN PRESSURE RATINGS INDICATED ON THIS SHEET.

ALUMINUM LOUVER SYSTEM ADEQUACY FOR IMPACT AND FATIGUE RESISTANCE HAS BEEN VERIFIED IN ACCORDANCE WITH SECTION 1626 OF THE ABOVE MENTIONED CODE AS PER PRI CONSTRUCTION MATERIALS TECHNOLOGIES, LLC. TESTING LAB REPORT # 1697T0001.01, AS PER TAS-201, TAS-202, TAS-203, AS WELL AS PER AMCA IMPACT STANDARD 540, PER TESTING REPORT # 1697T0001.03, AND AS PER AMCA STANDARD 550-15 HIGH VELOCITY WIND DRIVEN RAIN AND TAS 100(A)-95, PER TEST REPORT # 1697T0001.02 .

- 2. ALL ALUMINUM EXTRUSIONS SHALL BE 6063-T5 ALLOY AS PER BILL OF MATERIALS ON SHEET 2.
- 3. ALL SCREWS TO BE STAINLESS STEEL 304 OR 316 SERIES WITH 50 ksi YIELD POINT AND 90 ksi TENSILE STRENGTH OR CORROSION RESISTANT CARBON STEEL AS PER DIN 50018 AND SHALL COMPLY W/ FLORIDA BUILDING CODE SECTION 2411.3.3.4.
- 4. ALL WELDING OF ALUMINUM FRAMING SHALL BE IN ACCORDANCE WITH THE AMERICAN WELDING SOCIETY A.W.S. D.1.2 REGULATIONS. USE CERTIFIED WELDERS. USE ER-5356 ELECTRODES.
- 5. ANCHOR (10) TO EXISTING STRUCTURE SHALL BE AS FOLLOWS (SEE SHEETS 4 , 5).

(A). ANCHORS SHALL BE INSTALLED FOLLOWING ALL THE RECOMMENDATIONS AND SPECIFICATIONS OF THE ANCHORS MANUFACTURER. E.D. IS BEYOND ANY WALL FINISH.

ANCHOR TYPE	MANUFACTURER	DIAMETER OR GAGE	MIN. EMBEDMENT				MIN. EDGE DISTANCE (E.D.)		
			TO CONCRETE (f'c=3,000 psi) MIN.	TO CONCRETE BLOCK ASTM (C-90 UNIT) f'c=1.5ksi Grouted	1/8" MIN. ALUM. (Fy= 25ksi) or 14 GA. GALV. STEEL(Fy=33ksi)	TO WOOD (G ≥ 0.55)	CONCRETE OR CONCRETE BLOCK	STEEL	WOOD
SCREW-BOLT+	DEWALT	3/8"	3 1/4"	3 1/4"	N/A	N/A	1 1/2"	N/A	N/A
LAG SCREW	-	3/8"	N/A	N/A	N/A	1 1/2"	N/A	N/A	1 1/2"
TAP-FLEX	ELCO CONST.	3/8"	N/A	N/A	FULLY EMB. PLUS 3 THREADS BEYOND.	N/A	N/A	3/4"	N/A

- 6. MODEL WDV-130 ALUMINUM LOUVER SYSTEM MAY BE INSTALLED IN LOCATIONS WHERE THE ROOM BEHIND IS NOT DESIGNED TO DRAIN WATER PENETRATING INTO THE ROOM, OR THE ROOM WILL HOUSE NON-WATER RESISTANT EQUIPMENT. COMPONENTS OR SUPPLIES INSTALLATION ON LOUVER IS LIMITED TO 40 FT. IN HEIGHT ACCORDING TO TABLE 3 OF TAS 100(A)-95.
- 7. ALUMINUM MEMBERS IN CONTACT WITH DISSIMILAR MATERIALS SHALL COMPLY WITH SECTION III-6 OF THE 2015 ALUMINUM DESIGN MANUAL.

- 8. IT SHALL BE RESPONSIBILITY OF THE CONTRACTOR TO VERIFY THE SOUNDNESS OF THE STRUCTURE WHERE LOUVER SYSTEM IS TO BE ATTACHED TO INSURE PROPER ANCHORAGE.
- 9. (A). THIS PRODUCT APPROVAL DOCUMENT (P.A.D.) PREPARED BY THIS ENGINEER IS GENERIC AND DOES NOT PROVIDE INFORMATION FOR A SPECIFIC PROJECT; i.e. WHERE THE SITE CONDITIONS DEVIATE FROM THE P.A.D.
 (B). CONTRACTOR TO BE RESPONSIBLE FOR THE SELECTION, PURCHASE AND INSTALLATION INCLUDING LIFE SAFETY OF THIS PRODUCT, BASED ON THIS P.A.D., PROVIDED HE/SHE DOES NOT DEVIATE FROM THE CONDITIONS DETAILED ON THIS DOCUMENT. CONSTRUCTION SAFETY AT SITE IS THE CONTRACTOR'S RESPONSIBILITY.
 (C). THIS PRODUCT APPROVAL DOCUMENT WILL BE CONSIDERED INVALID IF MODIFIED.
 (D). SITE SPECIFIC PROJECTS SHALL BE PREPARED BY A FLORIDA REGISTERED ENGINEER OR ARCHITECT WHICH WILL BECOME THE ENGINEER OF RECORD (E.O.R.) FOR THE PROJECT AND WHO WILL BE RESPONSIBLE FOR THE PROPER USE OF THE P.A.D.
 (E). ORIGINAL P.A.D. SHALL BEAR THE DATE AND ORIGINAL SEAL AND SIGNATURE OF THE PROFESSIONAL ENGINEER THAT PREPARED IT.
- 10. PRODUCT MANUFACTURER'S LABEL SHALL BE LOCATED ON A READILY VISIBLE LOCATION AT PRODUCT IN ACCORDANCE WITH SECTION 1709.9.3 OF FLORIDA BUILDING CODE. ONE LABEL SHALL BE PLACED FOR EVERY OPENING. LABELING TO COMPLY WITH SECTION 1709.9.2 OF THE FLORIDA BUILDING CODE.

A.S.D. DESIGN PRESSURE RATING:
+150, -150 psf.

THIS DRAWING SHALL ONLY BE USED TO
OBTAIN PERMITS IN THE STATE OF FLORIDA

PRODUCT APPROVED
as complying with the Florida
Building Code
NOA-No. **20-0109.02**
Approval Date **02/27/2020**
By *[Signature]*
Miami-Dade Product Control

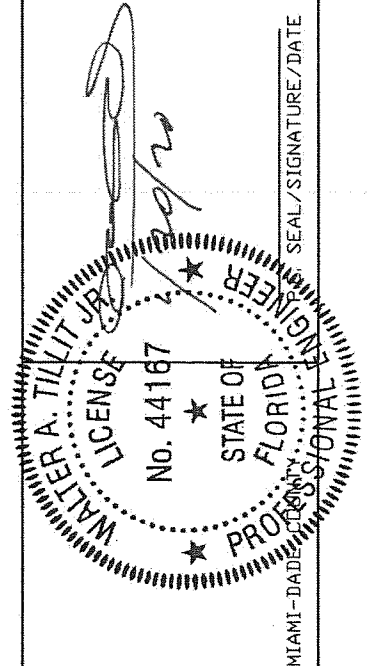

FLORIDA BUILDING CODE (HIGH VELOCITY HURRICANE ZONE)

MODEL WDV-130 VERTICAL ALUMINUM LOUVER SYSTEM

M.P. DRAWN BY: 9/24/19 DATE: 19-092 DRAWING No. SHEET 1 OF 6

UNITED ENERTECH HOLDINGS, LLC
159 GENCO DRIVE
3005 SOUTH HICKORY ST.
HARTFORD, AL 36344
PHONE: (423)698-7715 FAX:(423)698-6829

©2019 TILTECO, INC.
TILTECO INC.
TILLIT TESTING & ENGINEERING COMPANY
6355 N.W. 38th St., Ste. 305 VIRGINIA GARDENS, FL 33166
Phone : (305)871-1530 . Fax : (305)871-1531
WALTER A. TILLIT JR., P.E.
FLORIDA Lic. # 44167

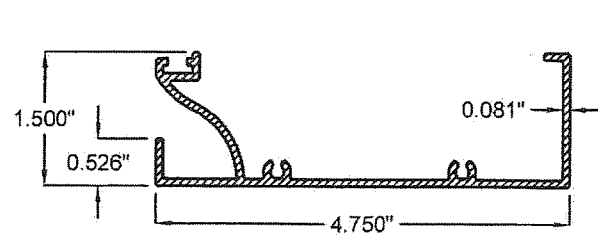

1 HEAD

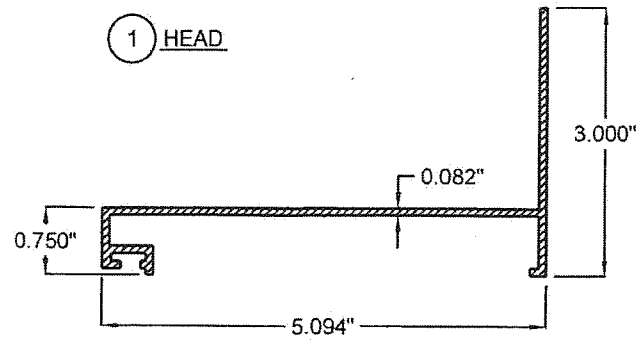

2 SILL

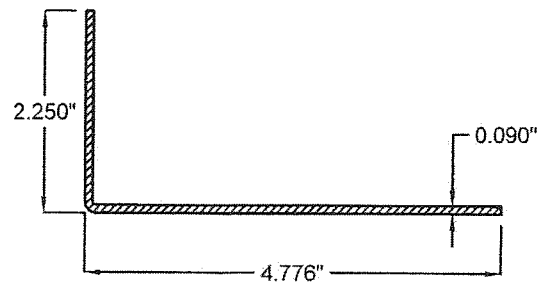

8 SILL BAFFLE

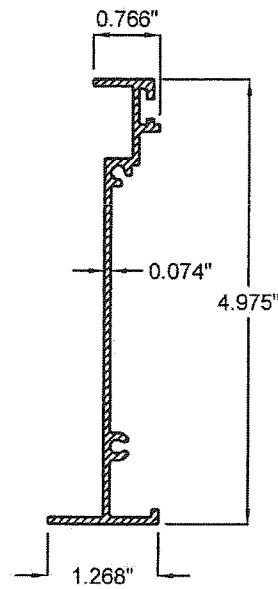

3 SIDE JAMB

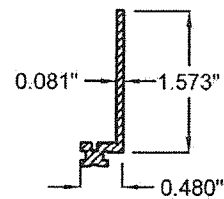

9 FLANGE

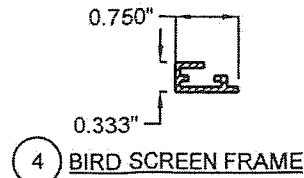

4 BIRD SCREEN FRAME

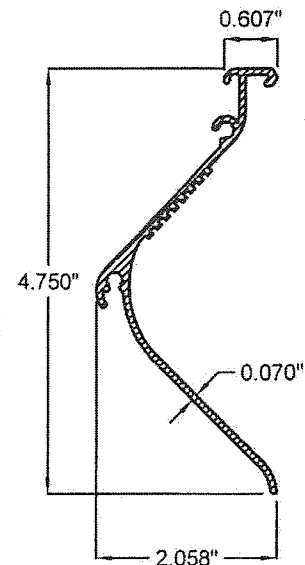

5 BLADE

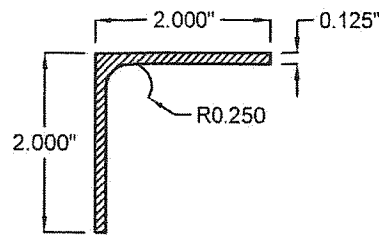

11 HEAD/SILL MOUNTING ANGLE (DOUBLES AS JAMB BLANK-OFF)

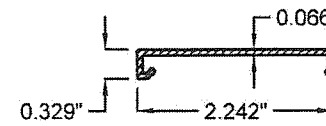

6 BLADE BRACE

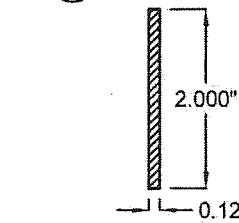

6A BLADE BRACE STRIP

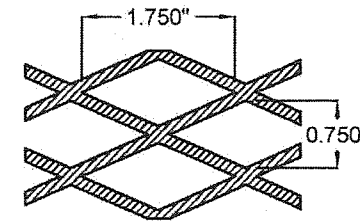

7 OPTIONAL BIRD SCREEN

COMPONENTS

BILL OF MATERIALS:

COMPONENT #	DESCRIPTION	MATERIAL	NOTES
1	HEAD	6063-T5 ALUMINUM ALLOY/TEMPER	CONTINUOUS
2	SILL	6063-T5 ALUMINUM ALLOY/TEMPER	CONTINUOUS USE W/ 8
3	SIDE JAMB	6063-T5 ALUMINUM ALLOY/TEMPER	CONTINUOUS
4	BIRD SCREEN FRAME	6063-T5 ALUMINUM ALLOY/TEMPER	OPTIONAL
5	BLADE	6063-T5 ALUMINUM ALLOY/TEMPER	WDV-130 MODEL
6	BLADE BRACE	6063-T5 ALUMINUM ALLOY/TEMPER	2" LONG
6A	BLADE BRACE STRIP	6063-T5 ALUMINUM ALLOY/TEMPER	CONTINUOUS ACROSS UNIT. SEE SHEET 3 FOR REQUIREMENTS.
7	STANDARD BIRD SCREEN	3/4" x 0.051" FLATTENED ALUMINUM	OPTIONAL
8	SILL BAFFLE	3003 H14 ALUMINUM ALLOY/HARDNESS	CONTINUOUS USE W/ 2
9	FLANGE	6063-T5 ALUMINUM ALLOY/TEMPER	OPTIONAL
10	ANCHOR	SEE GENERAL NOTE 5A/1	SEE DETAILS FOR SPACING SHEETS 4, 5
11	HEAD/SILL MOUNTING ANGLE, JAMB BLANK-OFF	6061-T6 ALUMINUM ALLOY/TEMPER	CONTINUOUS
12	#8 x 1-1/2" HEX HEAD, ZINC PLATED S.M.S.	-	USE AT FRAME ASSEMBLY
13	#10 x 1-1/2" HEX HEAD, ZINC PLATED S.M.S.	-	USE (2) FOR BLADE ATTACHMENT EA. END
14	1/4 -14 x 1-1/2" HEX HEAD, ZINC PLATED TEK SCREW	-	ANGLE CLIP ATTACHMENT TO HEAD & SILL
15	#10 x 3/4" HEX HEAD, ZINC PLATED TEK SCREW	-	BLADE BRACE ATTACHMENT & 11 ATTACHMENT

FLORIDA BUILDING CODE (HIGH VELOCITY HURRICANE ZONE)

M.P. DRAWN BY: 9/24/19 DATE: 19-092 DRAWING No. SHEET 2 OF 6

MODEL WDV-130 VERTICAL ALUMINUM LOUVER SYSTEM

UNITED ENERTECH HOLDINGS, LLC

3005 SOUTH HICKORY ST. 159 GENCO DRIVE CHATTANOOGA, TN 37407 HARTFORD, AL 36344 PHONE: (423)698-7715 FAX: (423)698-6629

REV. NO.	DATE	DESCRIPTION
1		
2		
3		
4		

©2019 TILTECO, INC.

TILTECO INC.

TILLIT TESTING & ENGINEERING COMPANY
6355 N.W. 36th St. Ste. 305 VIRGINIA GARDENS, FL 33166
Phone: (305)871-1530 Fax: (305)871-1531
CA-0006719
WALTER A. TILLIT Jr., P.E.
FLORIDA Lic. # 44167

WALTER A. TILLIT JR.
LICENSE No. 44167
STATE OF FLORIDA
PROFESSIONAL ENGINEER
MIAMI-DADE COUNTY
SEAL/SIGNATURE/DATE

PRODUCT APPROVED
as complying with the Florida Building Code
NOA-No. 20-0109.02
Approval Date 02/27/2020
By *[Signature]*
Miami-Dade Product Control

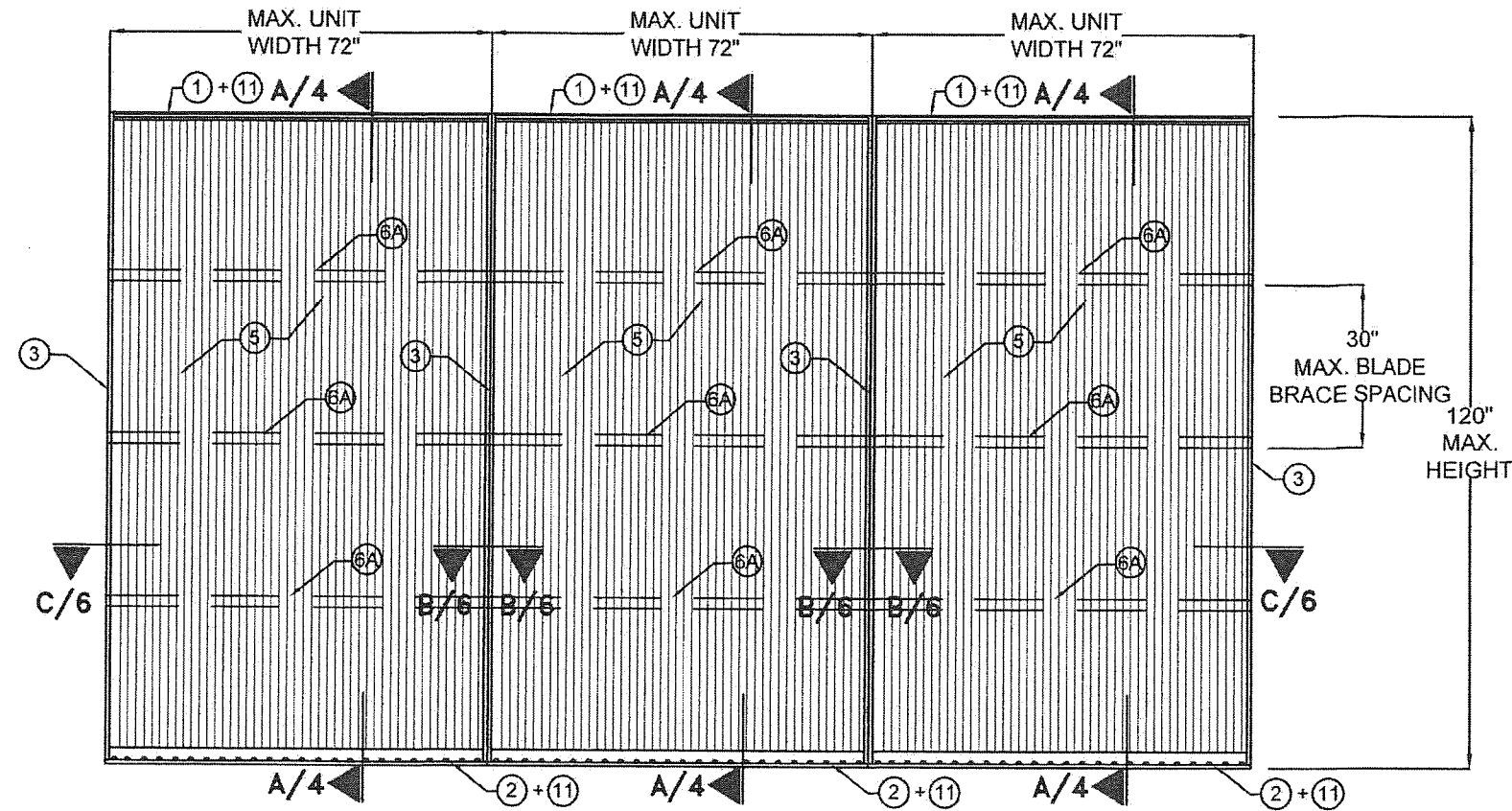

**EXTERIOR ELEVATION
MULTIPLE UNITS W/ 6A**

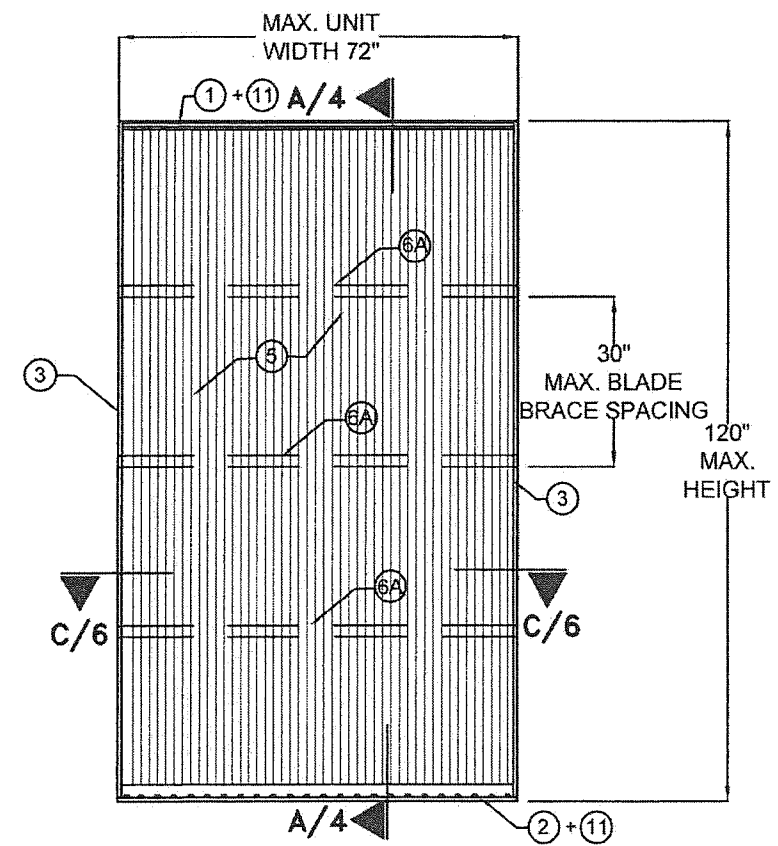

**EXTERIOR ELEVATION
SINGLE UNIT W/ 6A**

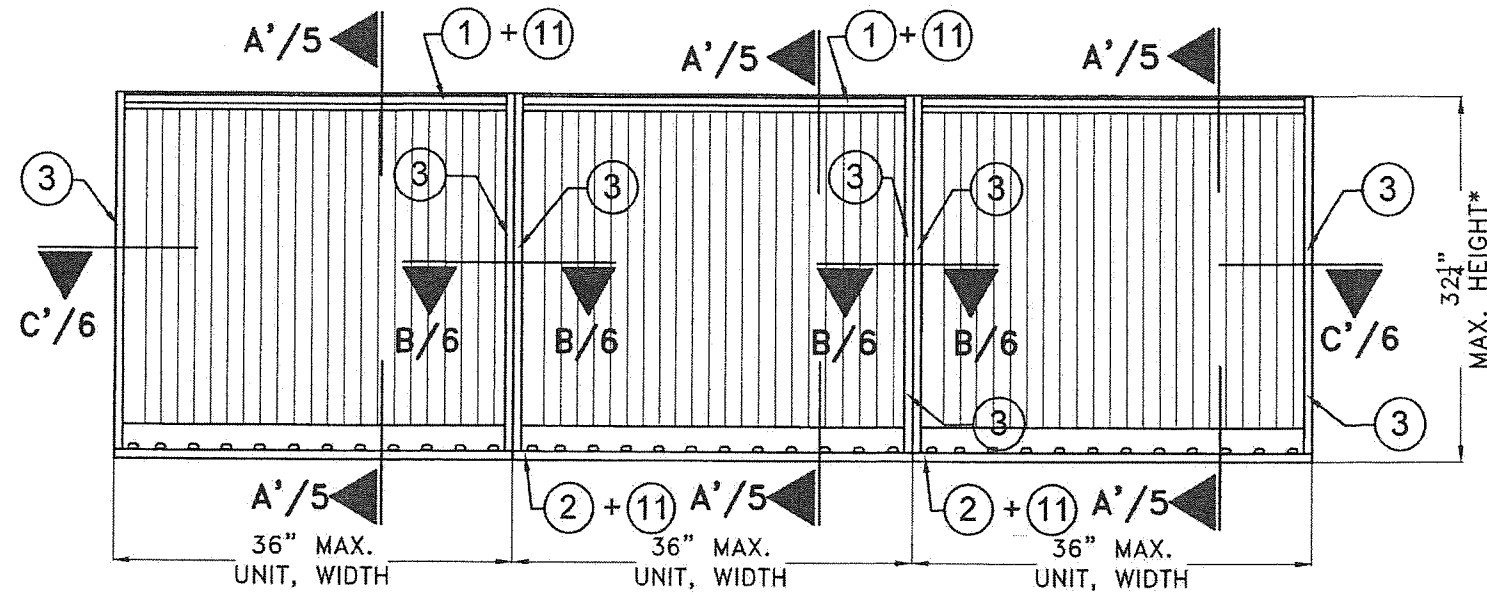

**EXTERIOR ELEVATION
(MULTIPLE UNITS W/O 6A)**

* MINIMUM HEIGHT IS 12" FOR AMCA 540 COMPLIANCE (IF REQUIRED)

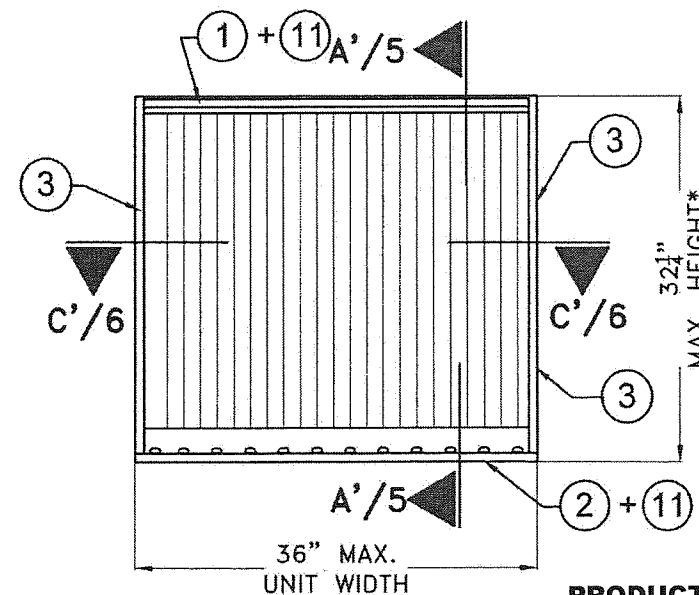

**EXTERIOR ELEVATION
SINGLE UNIT W/O 6A**

PRODUCT APPROVED
as complying with the Florida
Building Code
NOA-No. 20-0109.02
Approval Date 02/27/2020
By *[Signature]*
Miami-Dade Product Control

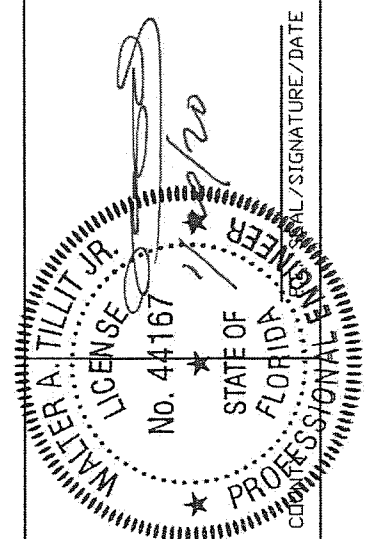

FLORIDA BUILDING CODE (HIGH VELOCITY HURRICANE ZONE)

©2019 TILTECO, INC.

TILTECO INC.
TILIT TESTING & ENGINEERING COMPANY
8355 N.W. 57th St., Suite 330, Fort Lauderdale, FL 33321
Phone: (305) 971-1530, Fax: (305) 971-1531
WALTER A. TILLIT JR., P.E.
FLORIDA Lic. # 44167

MODEL WDV-130
VERTICAL ALUMINUM LOUVER SYSTEM

UNITED ENERTECH HOLDINGS, LLC
3005 SOUTH HICKORY ST.,
CHATTANOOGA, TN 37407
PHONE: (423) 698-7715 FAX: (423) 698-6629

REV. NO.	DESCRIPTION	DATE	REV. NO.	DESCRIPTION	DATE
1			1		
2			3		

M.P. DRAWN BY: 9/24/19 DATE: 19-092 DRAWING No. SHEET 3 OF 6

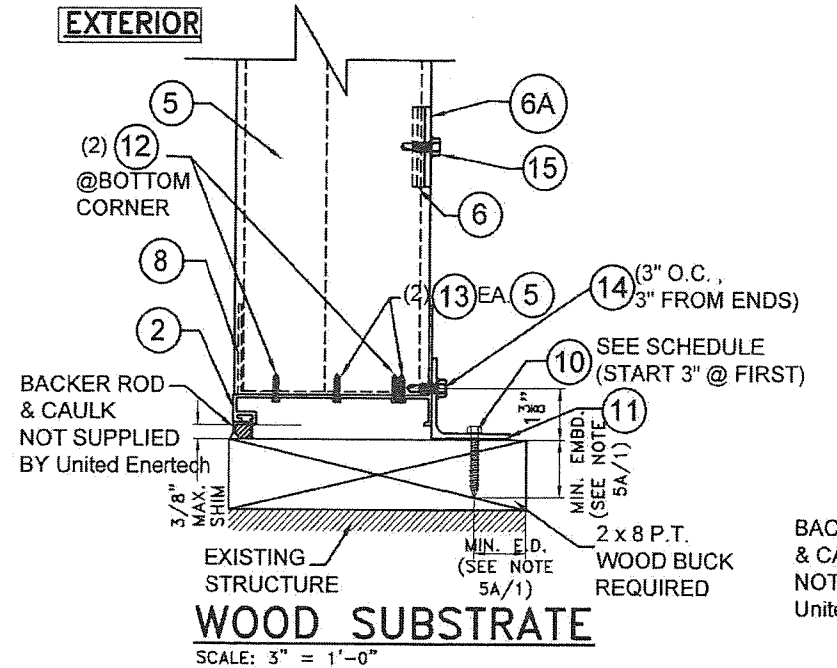
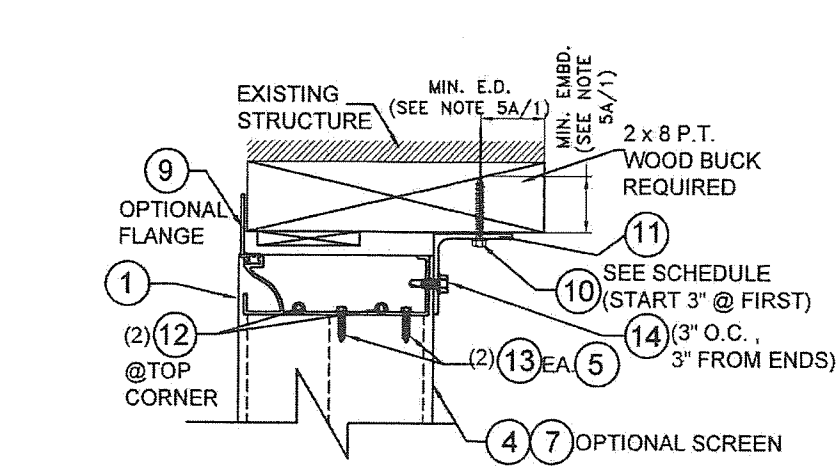

WOOD SUBSTRATE

SCALE: 3" = 1'-0"

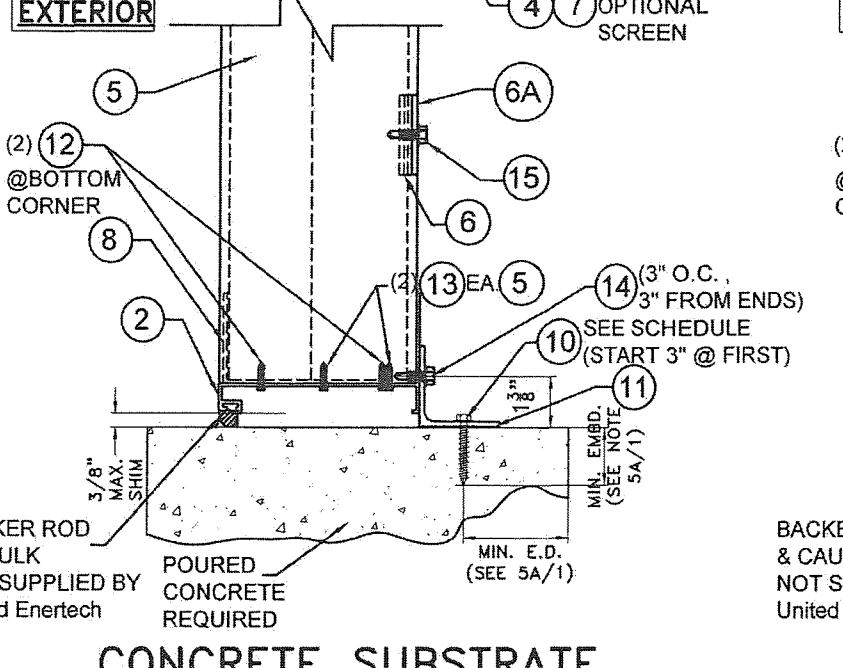
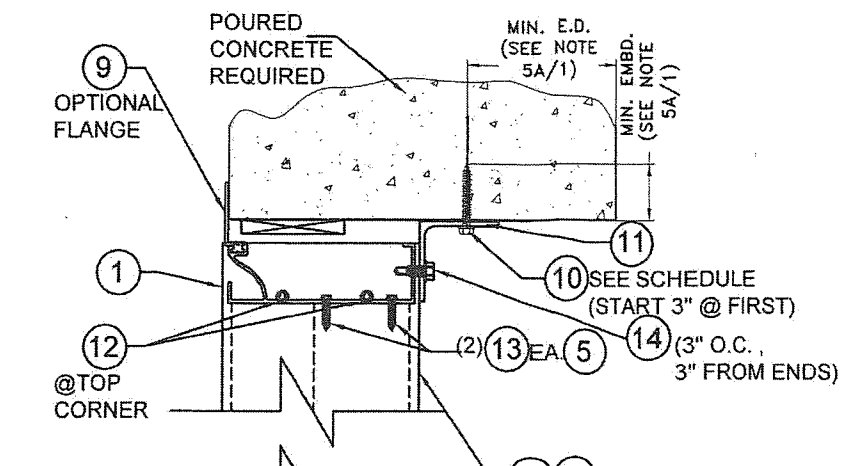

CONCRETE SUBSTRATE

SCALE: 3" = 1'-0"

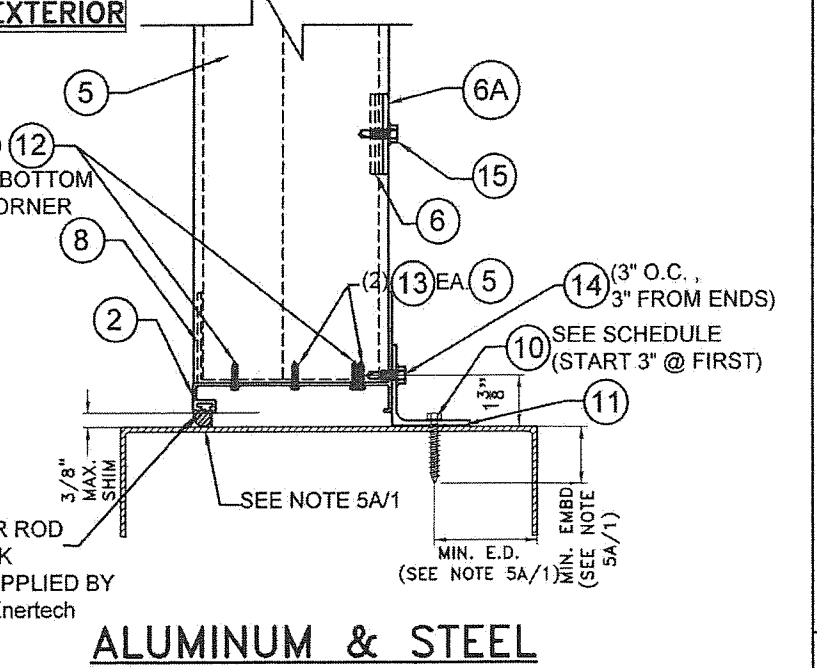
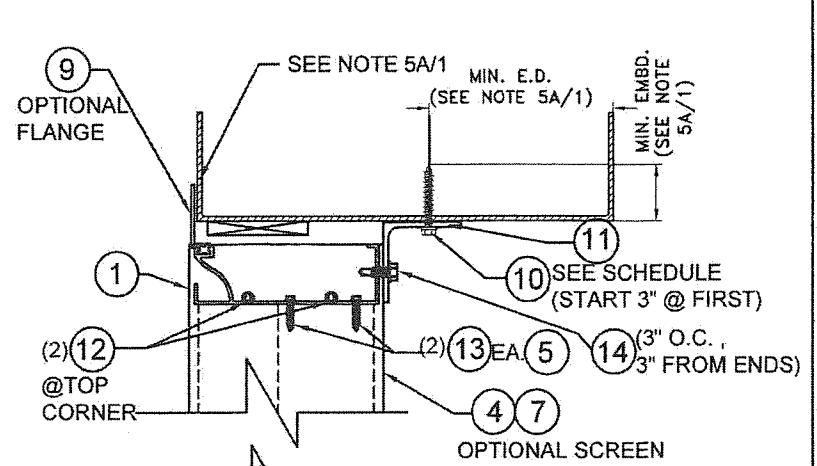

ALUMINUM & STEEL SUBSTRATE

SCALE: 3" = 1'-0"

SECTIONS A-A W/6A

MAX. ANCHOR (10) SPACING SCHEDULE AS PER NOTE 5A/1 AT ANGLE (11) TOP & BOTTOM

PRODUCT APPROVED
as complying with the Florida Building Code
NOA-No. **20-0109.02**
Approval Date **02/27/2020**
By *[Signature]*
Miami-Dade Product Control

A.S.D. DESIGN LOAD (p.s.f.)	MAX. UNIT HEIGHT (FT)	SUBSTRATE			
		CONCRETE	GROUTED CONCRETE BLOCK	WOOD	STEEL OR ALUMINUM
≤ 75.0	≤ 5'-0"	6" O.C.	6" O.C.	6" O.C.	6" O.C.
	> 5'-0" - 10'-0"	6" O.C.	6" O.C.	3 1/4" O.C.	6" O.C.
>75-150	≤ 5'-0"	6" O.C.	6" O.C.	3 1/4" O.C.	6" O.C.
	>5'-0" - 10'-0"	6" O.C.	4 1/2" O.C.	N/A	4" O.C.

FLORIDA BUILDING CODE (HIGH VELOCITY HURRICANE ZONE)

MODEL WDV-130
VERTICAL ALUMINUM LOUVER SYSTEM

©2019 TILTECO, INC.

TILECO INC.
TILIT TESTING & ENGINEERING COMPANY
156 Genco Drive
Chattanooga, TN 37407
Phone: (423) 698-7715 FAX: (423) 698-6629

UNITED ENERTECH HOLDINGS, LLC
156 Genco Drive
Chattanooga, TN 37407
Phone: (423) 698-7715 FAX: (423) 698-6629

REV. NO. 1 DESCRIPTION DATE
1 03 SPACING 7/20/20
2 - - - - -

M.P. DRAWN BY: 9/24/19 DATE:
19-092 DRAWING No.
SHEET 4 OF 6

WALTER A. TILLIT JR.
LICENSE No. 44167
STATE OF FLORIDA
PROFESSIONAL ENGINEER
MIAMI-DADE COUNTY

WALTER A. TILLIT JR., P.E.
FLORIDA Lic. # 44167

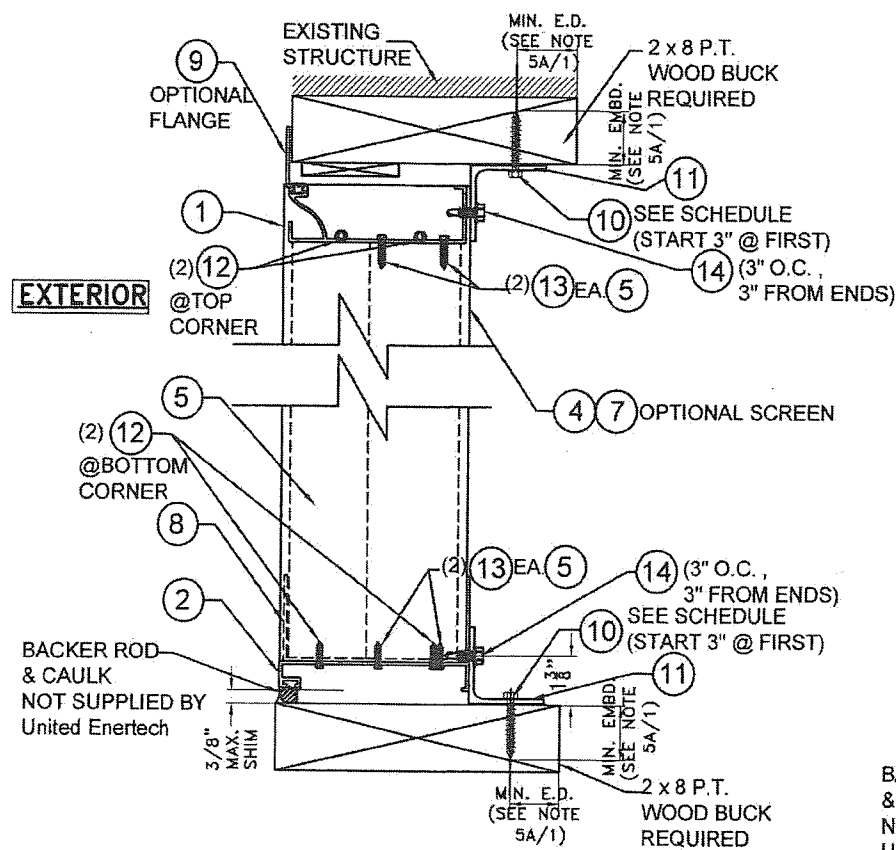

WOOD SUBSTRATE

SCALE: 3" = 1'-0"

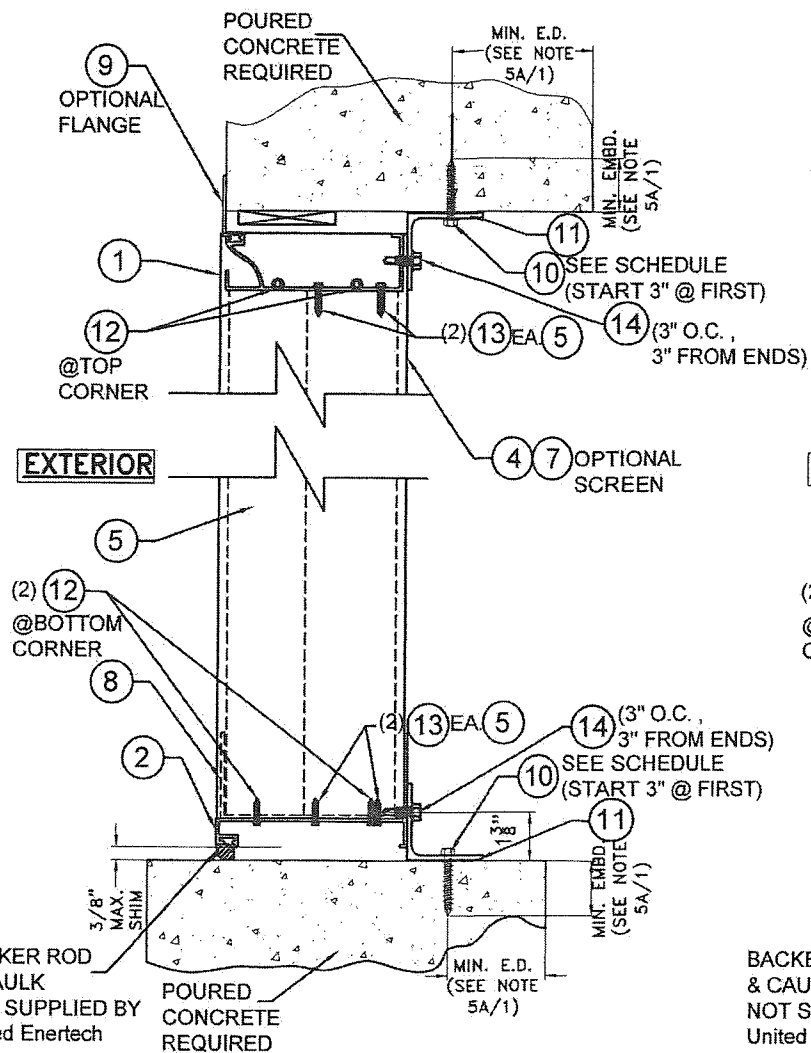

CONCRETE SUBSTRATE

SCALE: 3" = 1'-0"

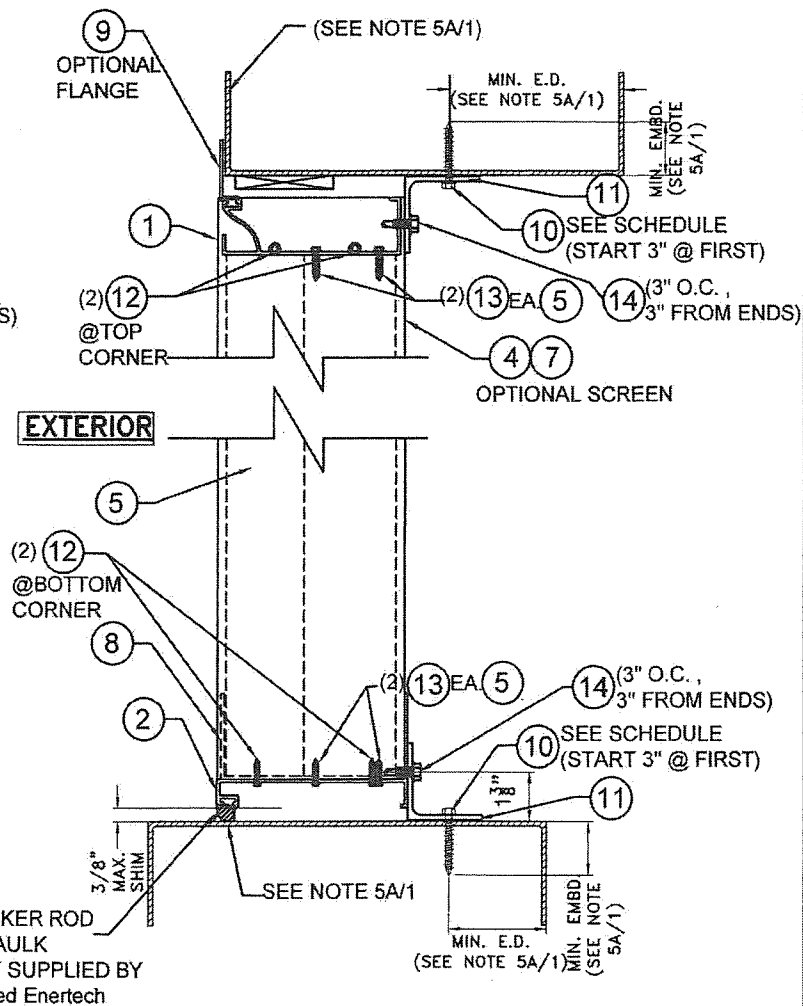

ALUMINUM & STEEL SUBSTRATE

SCALE: 3" = 1'-0"

SECTIONS A'-A' W/O (6A)

MAX. ANCHOR (10) SPACING SCHEDULE AS PER NOTE 5A/1 AT ANGLE (11) TOP & BOTTOM

PRODUCT APPROVED
as complying with the Florida Building Code
NOA-No. **20-0109.02**
Approval Date **02/27/2020**
By *[Signature]*
Miami-Dade Product Control

A.S.D. DESIGN LOAD (p.s.f.)	MAX. UNIT HEIGHT (FT)	SUBSTRATE			
		CONCRETE	GROUTED CONCRETE BLOCK	WOOD	STEEL OR ALUMINUM
≤ 75.0	≤ 5'-0"	6" O.C.	6" O.C.	6" O.C.	6" O.C.
	> 5'-0" - 10'-0"	6" O.C.	6" O.C.	3 1/4" O.C.	6" O.C.
> 75-150	≤ 5'-0"	6" O.C.	6" O.C.	3 1/4" O.C.	6" O.C.
	> 5'-0" - 10'-0"	6" O.C.	4 1/2" O.C.	N/A	4" O.C.

FLORIDA BUILDING CODE (HIGH VELOCITY HURRICANE ZONE)

MODEL WDV-130
VERTICAL ALUMINUM LOUVER SYSTEM

©2019 TILTECO, INC.

TILECO INC.
TILLIT TESTING & ENGINEERING COMPANY
1150 N.W. 36th St., Ste. 205, Virginia Gardens, FL 33186
Phone: (305) 671-1351 Fax: (305) 671-1351

UNITED ENERTECH HOLDINGS, LLC
159 GENCO DRIVE
HARTFORD, AL 36344
PHONE: (423) 698-7715 FAX: (423) 698-6629

M.P. DRAWN BY: 9/24/19 DATE: 19-092 DRAWING No. SHEET 5 OF 6

REV. NO	DESCRIPTION	DATE	REV. No	DESCRIPTION	DATE
1	SPACING	1/20/20	3		
2			4		

WALTER A. TILLIT JR.
LICENSED PROFESSIONAL ENGINEER
No. 44167
STATE OF FLORIDA
WALTER A. TILLIT JR., P.E.
FLORIDA Lic. # 44167

MIAMI-DADE COUNTY PROFESSIONAL ENGINEER

DATE

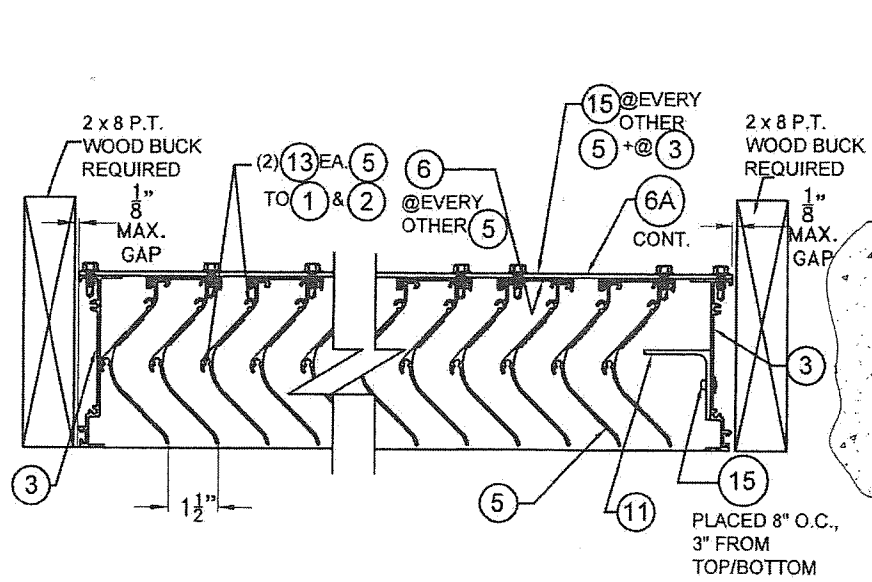

WOOD SUBSTRATE
N.T.S.

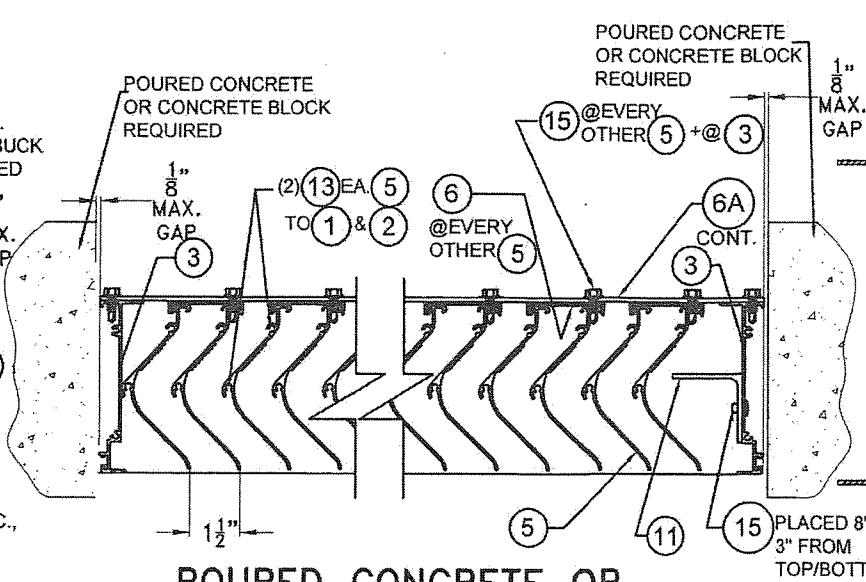

POURED CONCRETE OR CONCRETE BLOCK SUBSTRATE
N.T.S.

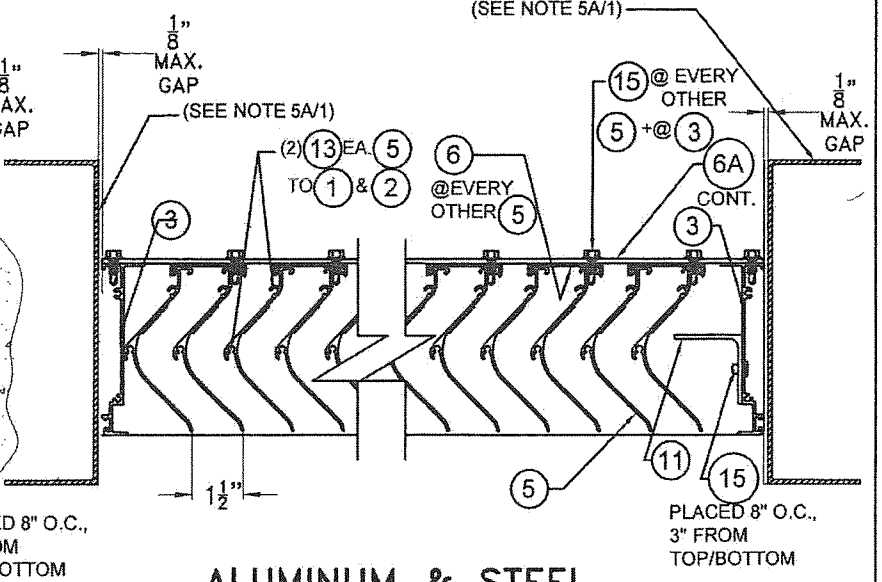

ALUMINUM & STEEL SUBSTRATE
N.T.S.

SECTIONS C-C W/ (6A)
N.T.S.

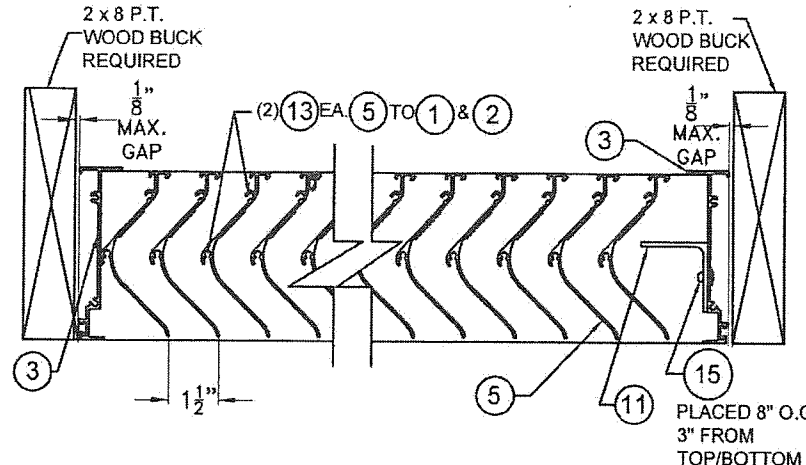

WOOD SUBSTRATE
N.T.S.

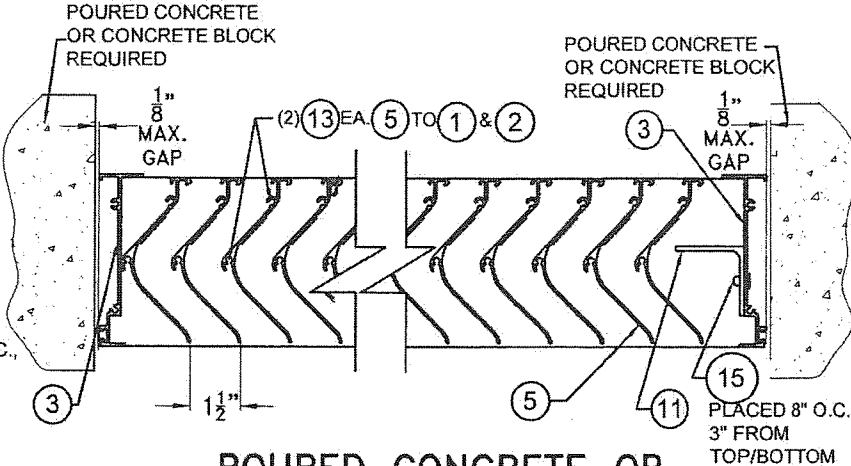

POURED CONCRETE OR CONCRETE BLOCK SUBSTRATE
N.T.S.

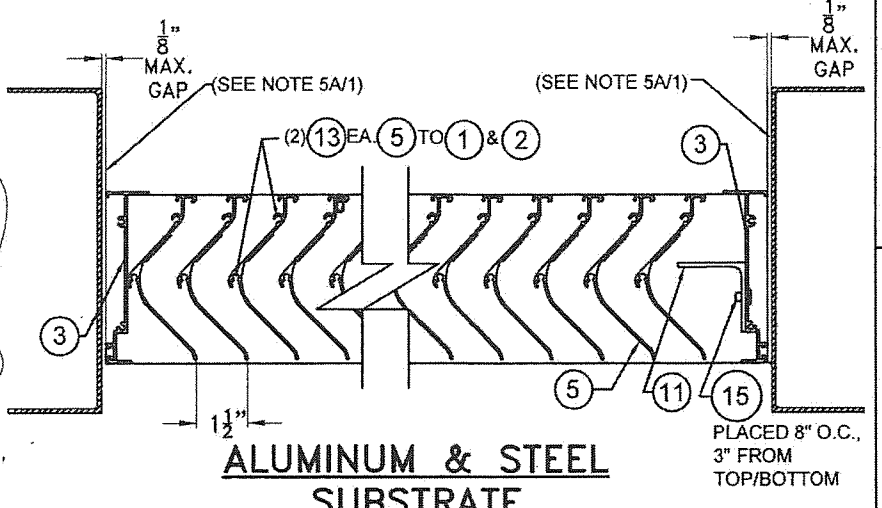

ALUMINUM & STEEL SUBSTRATE
N.T.S.

SECTIONS C'-C' W/O (6A)
SCALE: 3" = 1'-0"

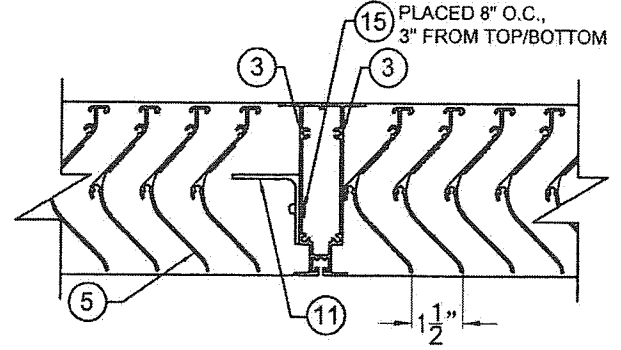

SECTION B-B
N.T.S.

(SEE NOTE 5A/1)

FLORIDA BUILDING CODE (HIGH VELOCITY HURRICANE ZONE)

M.P. DRAWN BY: 9/24/19 DATE: 19-092 DRAWING No. SHEET 6 OF 6	
MODEL WDV-130 VERTICAL ALUMINUM LOUVER SYSTEM	
UNITED ENERTECH HOLDINGS, LLC	
5005 SOUTH HICKORY ST. HARTFORD, AL 35344	
CHATTANOOGA, TN 37407 PHONE: (423)698-7715 FAX: (423)698-6623	
REV. NO.	DATE
1	
2	

©2019 TILTECO, INC.

TILECO INC.

TILLIT TESTING & ENGINEERING COMPANY
1501 S.W. 15th St., Virginia Gardens, FL 33166
Phone: (305)975-1515 Fax: (305)971-1531

WALTER A. TILLIT, JR., P.E.
FLORIDA LIC. # 44167

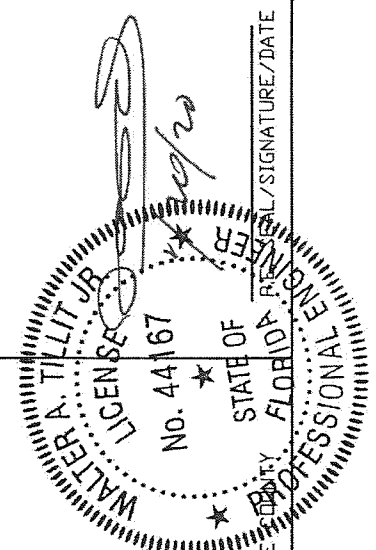

PRODUCT APPROVED
as complying with the Florida Building Code
NOA-No. **20-0109.02**
Approval Date **02/27/2020**
By *[Signature]*
Miami-Dade Product Control

MIAMI-DADE COUNTY PROFESSIONAL ENGINEER SIGNATURE/DATE